

Polypropylene Hand Nozzle with Female Base

DM-95HFR Series • *Xtreme Duty Dispensing* for Pump or Gravity Feed

Benefits...

- Increase environment safety with careful fluid control
- Prevents spillage during critical transfer operations
- Simplifies liquid repacking into smaller containers
- Fine gravity or pressure dispensing of most liquids
- Female NPT base thread or hose barb connections



DM-95HFR Series Polypropylene Nozzle

Applications & Features

Used for bulk liquid transfer from pumps, from processing equipment under pressure or gravity transfer from storage containers; for repacking bulk liquids into smaller containers, and other applications. Heavy Duty nozzle has a strong, unbreakable stainless steel trigger. A nozzle Spout Extension Kit extends nozzle reach by 10-36" for better dispensing reach and Operator safety.

Six Models

Description MOC's: Hi-chemical resistance for compatible liquids with polypropylene, SS, Viton

DM-95HFR/V12N	Hand dispensing nozzle, 1/2" female- base, NPT pipe thread
DM-95HFR/V34N	Hand dispensing nozzle, 3/4" female-base, NPT pipe thread
DM-95HFR/V100N	Hand dispensing nozzle, 1" female-base, NPT pipe thread
DM-95HFR/V12B	Hand dispensing nozzle, 1/2" hose barb
DM-95HFR/V34B	Hand dispensing nozzle, 3/4" hose barb
DM-95HFR/V100B	Hand dispensing nozzle, 1" hose barb

Specifications

All models: **Flow Range:** 0-60 Gpm, **Pressure:** 0-75 Psi., **Temperature:** 32° to 150°F* (See WARNING below!)
 Nozzle dims: **Spout:** 0.75" ID x 1.0" OD x 5.5" Spout Length, **Hose Barbs:** 1/2", 3/4", 1.0" OD

Accessories

Product code

Description

Spout Extension Kit	DM-800SEK.99	Spout Extension can increase spout length from 10 to 36 inches
Safety Swivel	DM-100SHS	Safety swivel prevents operator wrist injury, hose crimping or coiling
Spare Hose Barbs	DM-95HBA/V_ "	Viton hose barb assembly, specify 1/2", 3/4", or 1.0" size
O-ring Service Kits	DM-95HFR/RKV	Viton Service Kit, set of 3 seals, for all nozzle models
Drip Prevention Cap	DM-95NDC	Spout drip cap, helps prevent residue drips, Disposable, vinyl
Dispensing Hose:	DM-85CDH/A34	Flexible polypropylene transfer hose, 3/4" ID x 3 ft., hose clamp
	DM-85CDH/CL34	Hose only, as above, but lengths to 50 feet in 1 ft. increments
	DM-85PDH/A	Flexible reinforced PVC hose, 1" & 3/4" ID x 3 ft., with hose clamp

Spare Parts & Accessories

Part List

Part Number

Nozzle handle	DM95VN10253
Nozzle body	DM95VN10254
O-ring, trigger stem	DM95VN10263
O-ring, nozzle body	DM95VN10264
Nozzle snap ring	DM95VN10265
Nozzle plug	DM95VN10269
Nozzle poppet	DM95VN10270
Nozzle trigger stem gasket	DM95VN10271
Nozzle trigger stem	DM95VN10273
Nozzle trigger spring, SS	DM95VN10274
Hose barb assembly, 1/2"	DM-95HBA/12
Hose barb assembly, 3/4"	DM-95HBA/34
Hose barb assembly, 1"	DM-95HBA/100

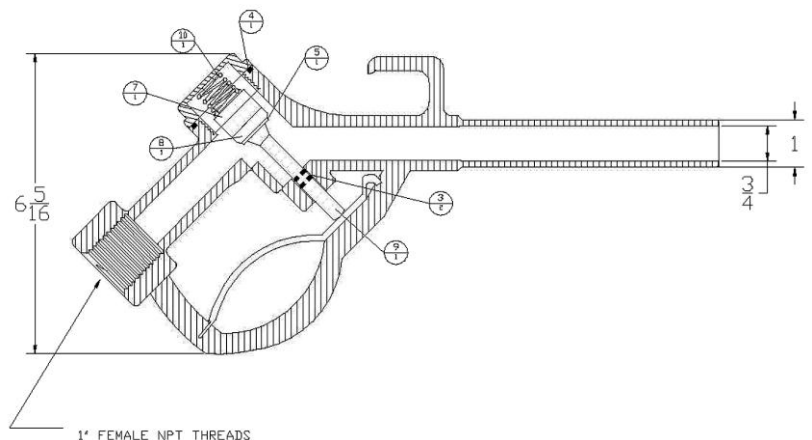

***WARNING!** Temperatures from 105° to 125°F **not recommended** without adequate safety protection gear. Ask for literature on DRUM-MATES® drum & tote mixers, drum tumblers, drum & tote pumps & hand nozzles. DRUM-MATES® Inc., Mixer & Pump Div., Tel: 1-800-621-3786 and 609-261-1033, Fax: 609-261-1034